

Ambrogio Robot L60

MD-CO-RO-21 - Rev. 3.2 - 01/12/2014 - Ambrogio Robot L60

Spare Parts Catalogue

Previous Revision **3.1**
Current Revision **3.2**
 From **2015-01**

Rif. Verde significa compatibile con il codice precedente
Rif. Green means compatible with the previous code

L60BEU **Ambrogio Robot L60 B** Models Type Included

MODEL REVISION	REVISIONE MODELLO
V01 MODELS	MODELLI V01
Robots produced with IMS Wheels Motor without reference 4 in the serial number	Robot prodotti con Motori Ruota IMS Senza la referenza 4 nel numero di serie
W I 2 0 0 L W 1 1 3 0 1 0 0 0 1	
V02 MODELS	MODELLI V02
Robots produced with FS Wheels Motor reference 4 in the serial number.	Robot prodotti con Motori Ruota FS referenza 4 nel numero di serie.
W I 2 0 0 L W 4 1 3 0 1 0 0 0 1	

Price List. Only for Italy. Delivery cost not included
Listino al pubblico. Trasporto non incluso



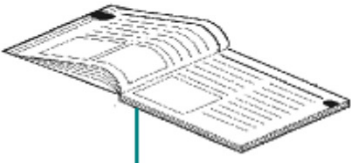

1

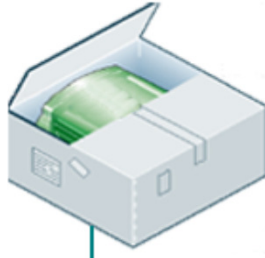

2



3



4

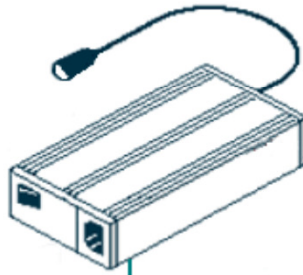

5



7

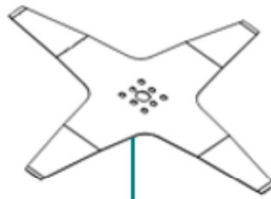

8

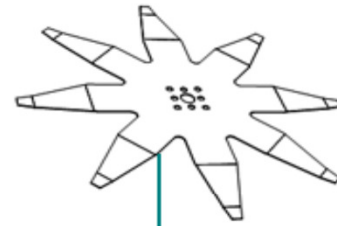

9



10



11

Rif.	Code	Qt.in Robot		(IT) Descrizione * (GB) Description	MOQ	L T A
1	60_ML_AM-V14	1	L60	(EU) - Manuale d'uso - User's Manual	1	0
1		1		-		
2	50_D0035_00	1		(EU) - Imballo Robot - Robot Packaging	1	0
2	50_D0034_00	1		(EU) - Imballo Esterno - External Packaging	1	0
2		1		-		
3	CS_C0109	1	200 Gr	Grasso - Grease	1	0
4	50_C0008_00	1	Schuko	Cavo Alimentazione - Supply Cable	1	0
4	50_C0004_00	1	USA	Cavo Alimentazione - Supply Cable	1	0
4	50_C0011_00	1	GB	Cavo Alimentazione - Supply Cable	1	0
4	50_C0012_00	1	CH	Cavo Alimentazione - Supply Cable	1	0
5	HLN60H29ZU	1	29.3V Li-ion	(2.3Ah) Caricabatteria - Battery Charger	1	13
7	50_E0011_00	1		Kit Ricarica - Kit for Charging	1	0
8	50_D0018_02	1	4KB Ø24 Cm	Lama piegata a 4 Punte - 4 knives bent blade	1	0
9	050Z06000A	1	8KB Ø24 Cm	Lama piegata a 8 Punte - 8 knives bent blade	1	0
10	50_D0056_00	1		Disco Pulente - Cleaning Plate	1	0
11	AMBCAPROG	1		Programming Cable - Cavo Programmazione	1	0

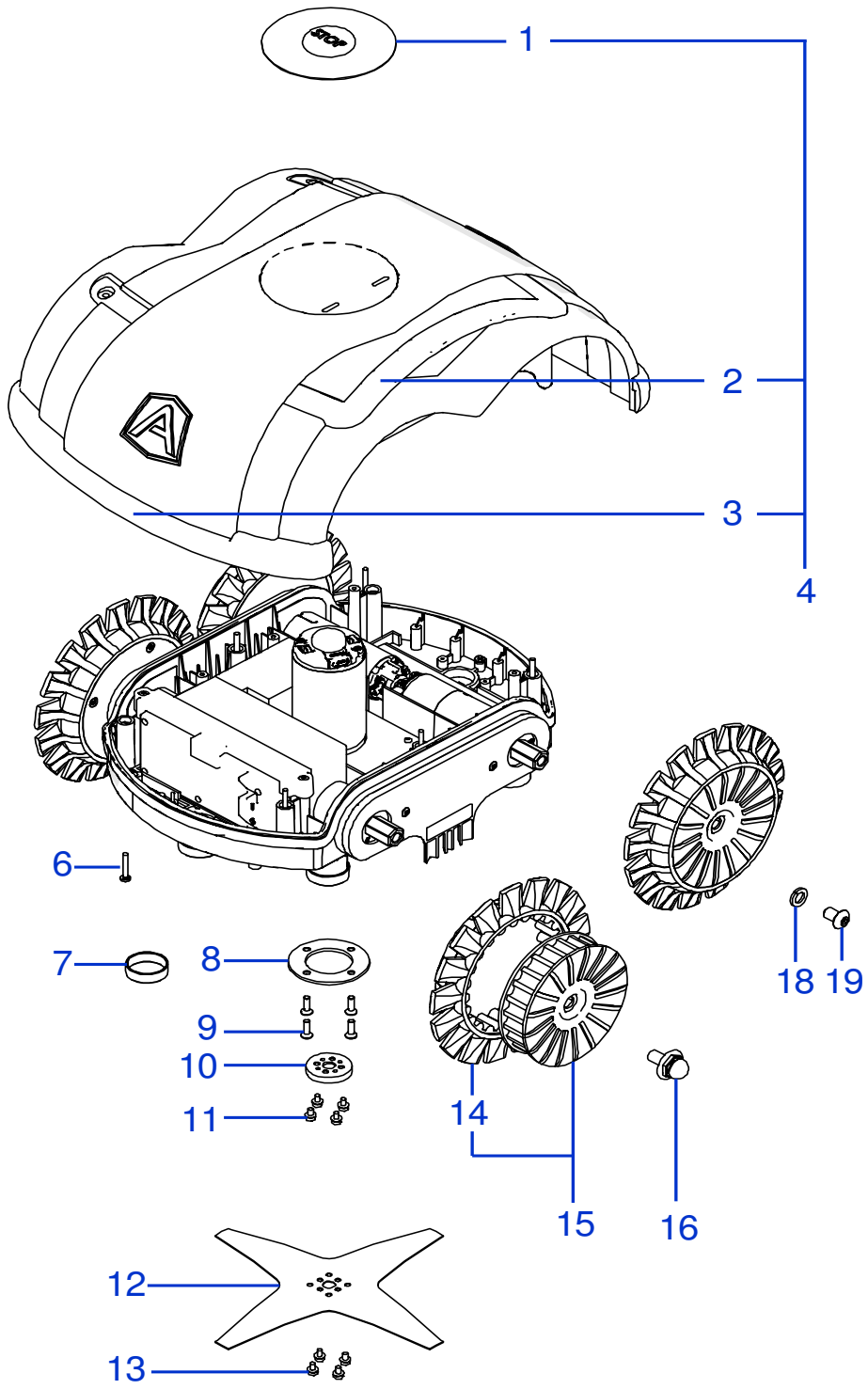

Rif.	Code	Qt.in Robot		(IT) Descrizione * (GB) Description	MOQ	L T A
1	050Z27800A	1		Tasto - Key (On-Off / Start-Pause)	1	13
2	050Z02800A	2		Maniglia - Lifting handle	1	0
3	050Z02700A	2		Paraurti - Bumper	1	0
4	050Z28600A.R	1	B	Gruppo Calotta - Cap Set	1	3
6	C00580	6		Vite - Screw	100	0
7	050Z27500A	6		Anello - Ring	6	0
8	50_D0016_00	1		Supporto Motore - Motor Support	1	0
9	C00041	4	M5X16	Vite - Screw	100	0
10	50_D0019_00	1		Distanziale - Spacer	1	0
11	C00212	4	M4X8	Vite - Screw	100	16
12	50_D0018_02	1	4KB Ø24 Cm	Lama piegata a 4 Punte - 4 knives bent blade	1	0
13	C00212	4	M4X8	Vite - Screw	100	16
14	050Z04800A	4		Ø 176 - Copertone - Tire	1	0
15	050Z05000A_G	2		Denti ruota interni - Internal wheel teeth	1	0
15	050Z05100A_G	2		Denti ruota esterni - External wheel teeth	1	0
16	50_D0017_00	2		Pomelli Ricarica - Charging Bolt	1	0
18	C00217	2		Rondella - Washer	10	6
19	C00161	2	M10X16	Vite - Screw	10	0

Paraurti - Bumper
Pulire la superficie ed incollare con Loctite 406
Clean the surface and glue with Loctite 406

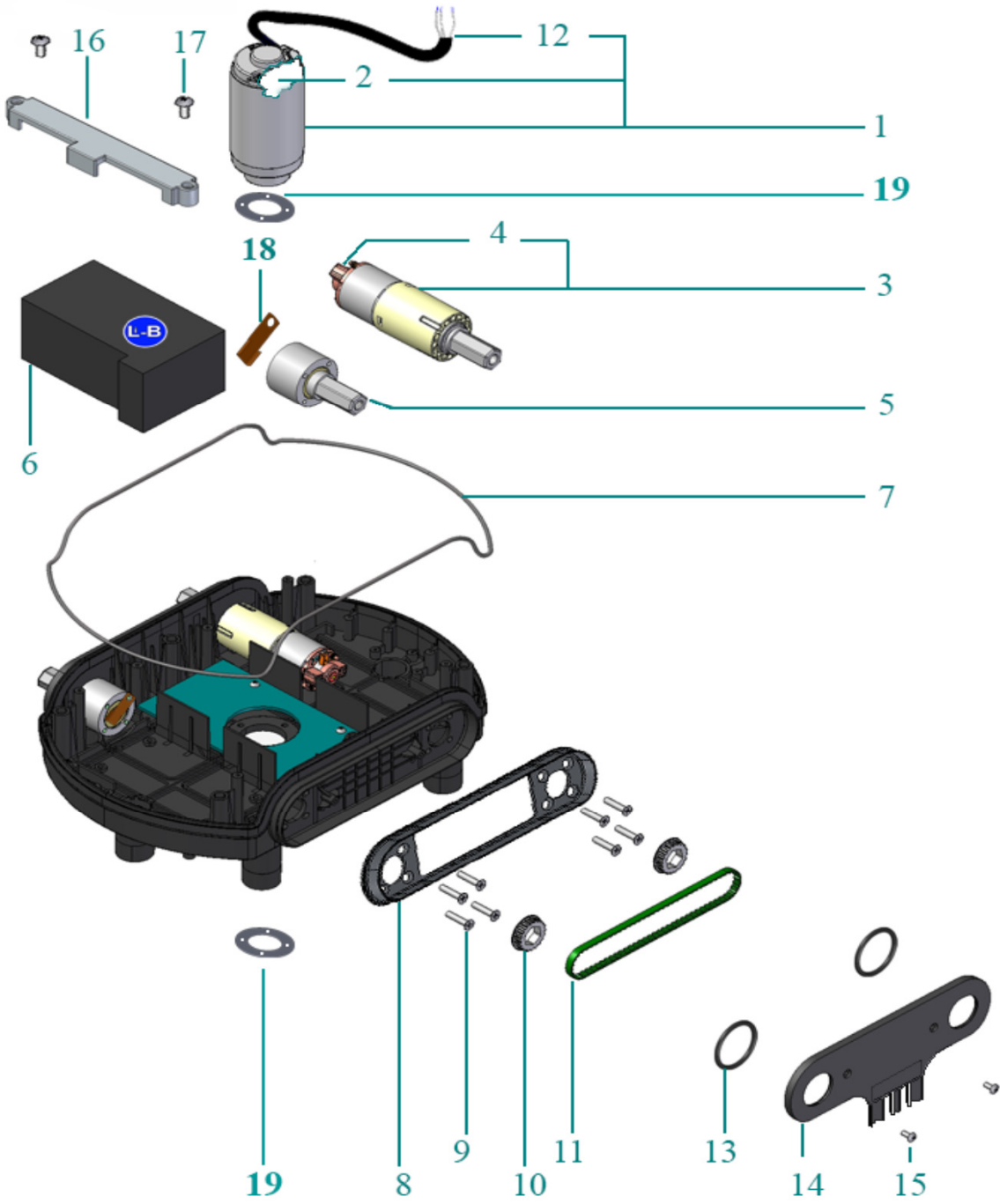

Tav. **03** **0**

Taf. _____

Rif.	Code	Qt.in Robot		(IT) Descrizione * (GB) Description	MOQ	L T A
1	CS_C0009/F	1	24V-25-4000	Motore di Taglio - Cutting Motor	1	16
2	CS_C0121_01	1		(FS) - Kit Spazzole e Portaspazzole - Brush & Brush housing	1	26
V01 MODELS						MODELLI V01
3	50_A0005_00	2	IMS Brand	(IMS) - Motoriduttore - Motor Reducer	1	19
4	300_C0300	4	10x5x5	(IMS) - Spazzola - Brush	1	19
V02 MODELS						MODELLI V02
3	50_A0008_00	2	FISE Brand	(FS) - Motoriduttore - Motor Reducer	1	19
4	075_D0014	4		(FS) - Spazzola - Brush	1	19
5	50_A0002_00	2		(EU) - Perno Ruota Libero - Free wheel pin	1	12
6	CS_C0106/1	1	Lithium (25.2V 6.9A)	(Type B) - Batteria - Battery	1	0
7	050Z22800A	1		Guarnizione - Gasket	1	0
8	050Z06600A	2		Piastra - Plate	1	0
9	C00205	16	M5X22	Vite - Screw	100	0
10	50_D0004_01	4	(2009) Model	(Obsolete) Puleggia - Pulley	1	7
10	050Z06300A.3	4	(2010) Model	Puleggia - Pulley (Use only with C00536)	1	7
11	50_C0001_00	2	(2009) Model	(Obsolete) Cinghia - Belt	1	7
11	C00536	2	(2010) Model	Cinghia - Belt (Use only with 050Z06300A)	1	7
12	50_E0003_00	1		(FS) - Encoder Lama - Blade encoder	1	19
13	50_C0002_00	4		Oring - Oring	10	0
14	50_D0027_01	2		Carter - Carter	1	0
14	50_D0027_00	2	for smaller wheels	Carter senza pinne - Carter without protective edges	1	0
15	C00208	4	M4X25	Vite - Screw	100	0
16	50_D0041_00	1	Only x Lithium 6.9	Fissaggio Batteria - Battery Clamp	1	0
17	C00210	2	M4X12	Vite - Screw	100	0
18	050Z04400A	2		Molla - Spring	1	0
19	050Z06700A	2		Guarnizione - Gasket	10	0

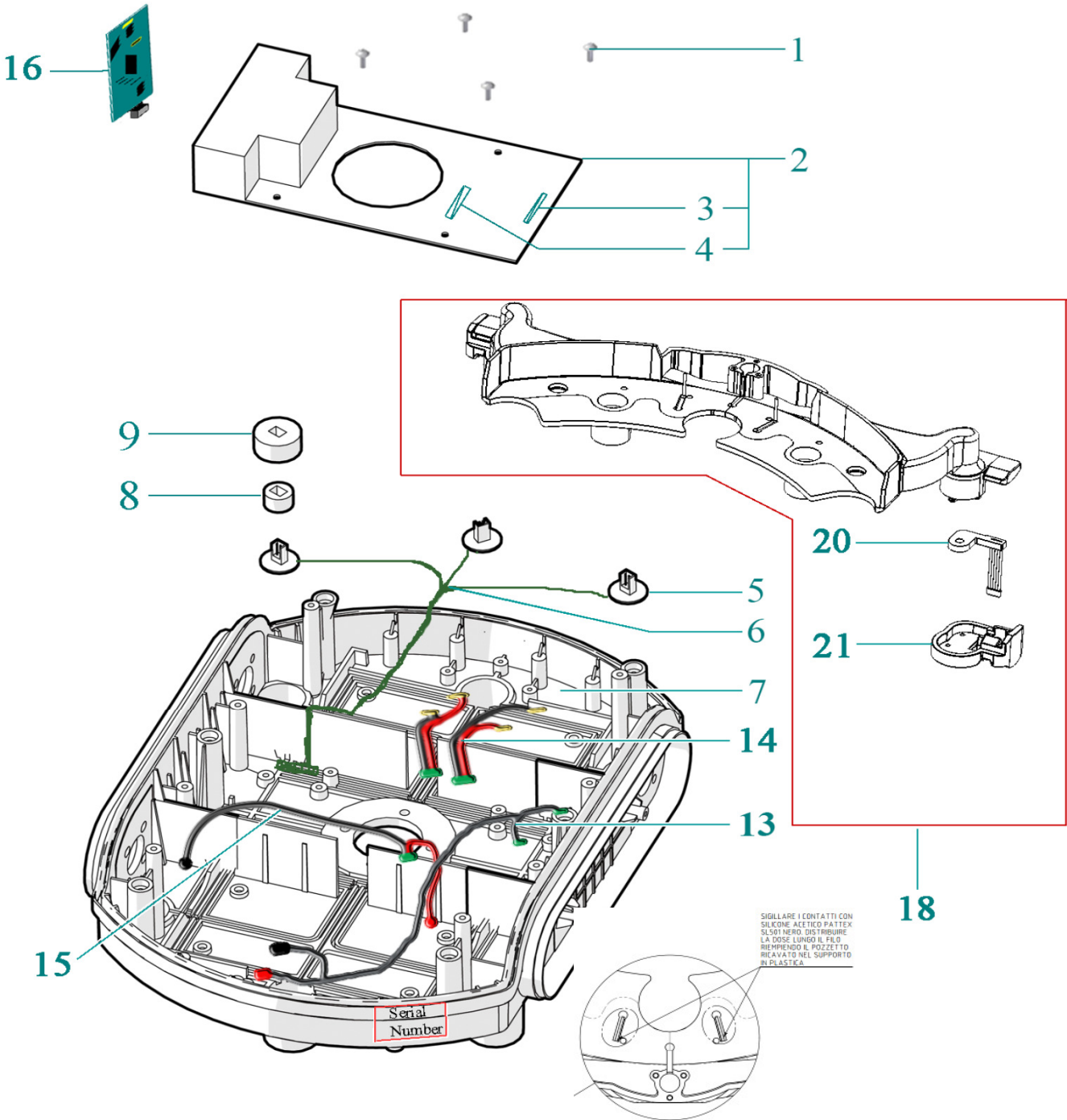

Tav. **04** **0**
 Tab.
 Taf.

Rif.	Code	Qt.in Robot		(IT) Descrizione * (GB) Description	MOQ	L T A
1	C00214	4	M3X10	Vite - Screw	100	0
2	50_SMEU_01	1	Basic/Deluxe	Scheda Madre - Mother Board	1	20
3	A210541	1	32V 20A	Fusibile - Fuse	10	0
4	A210540	1	32V 1A	Fusibile - Fuse	10	0
5	50_E0007_00	6		Sensore Erba - Grass Sensor	1	15
6	50_E0006_00	2		Cavo - Wire	1	0
7	50_D0021_00	1		Scocca - Body	1	0
8	50_D0048_00	6	D16 Sp10	Guarnizione - Gasket	20	0
9	50_D0047_00	6	D26 Sp13	Guarnizione - Gasket	20	0
				-		
13	50_E0004_00	1		Cavo Batteria - Battery Wire	1	0
14	50_E0010_00	2		Cavo Motore Ruota - Wheel Motor Wire	1	0
15	50_E0005_00	1		Cavo Ricarica - Recharging Wire	1	0
16	051E00400A	1	x M.Board 6.x 7.x	Ricevitore Bluetooth - Bluetooth Receiver	1	7
18	050Z28100A	2		Gruppo Baratro - Drop-Off Group	1	0
2x18	K-050Z28100A	1	Basic-Upgrade	Kit baratro + Cavi - Curb drop-off + wire Kit	1	0
20	050Z28400A	2	V2014	Sensore Destro - Right Sensor	1	16
20	050Z28200A	2	V2014	Sensore Sinistro - Left Sensor	1	16
21	050Z14000A.2	2	DX	Copertura - Cover	1	0
21	050Z13200A.2	2	SX	Copertura - Cover	1	0