

Ambrogio CUBE Elite

MD-CO-RO-42- Rev. 1.0 - 31/01/2024 - Ambrogio CUBE Elite

Spare Parts Catalogue

Previous Revision
Current Revision

1.0
1.0

From

2024-01

Models Type Included

D095ELU

Elite

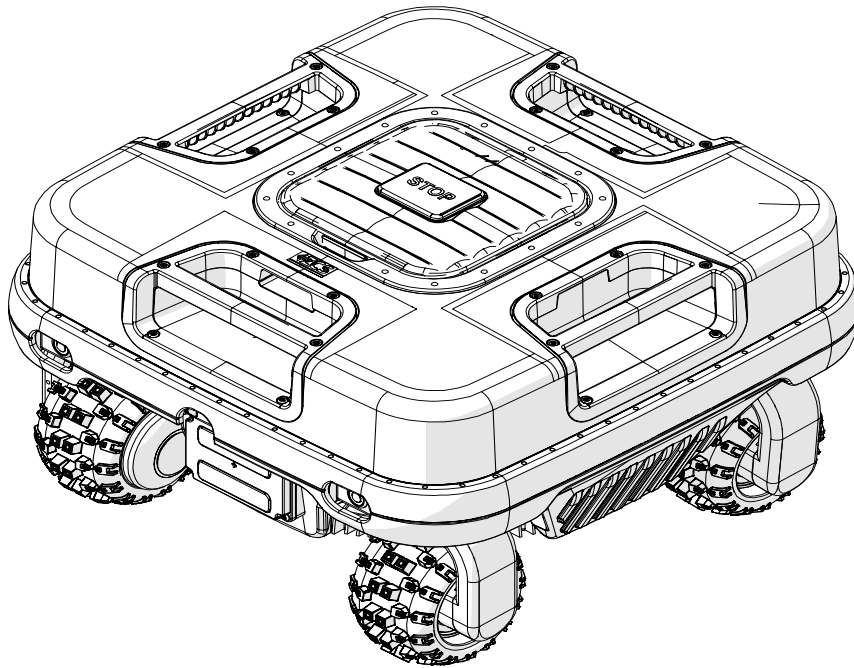

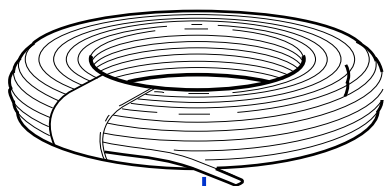

1



2

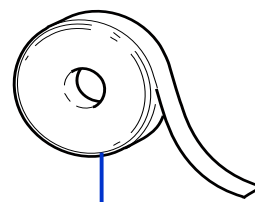

3

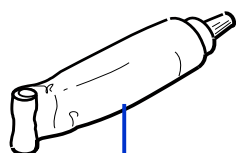

4

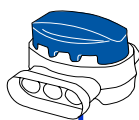

5

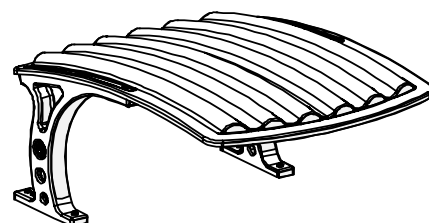

6

Tav. 01 0
 Tab.
 Taf.

Rif.	Code	Qt.in Robot		(IT) Descrizione * (GB) Description	MOQ
1	CS_E0002OS	1	MT 100	Cavo - Cable	1
1	CS_E0002	1	MT 150	Cavo - Cable	1
1	CS_E0002_3	1	MT 300	Cavo - Cable	1
1	CS_E0002_5	1	MT 500	Cavo - Cable	1
1	CS_E0002_10	1	MT 1000	Cavo - Cable	1

Consegna in 60 giorni dall'ordine - Delivery Time 60 days from order date

2	200A00100A	0-1	(100 Pz)	Conf. Chiodi - Nails Bag	1
2	200A00200A	0-1	(200 Pz)	Conf. Chiodi - Nails Bag	1
3	CS_C0111	0		Nastro Agglomerante - Stretch Electrical Tape	1
4	CS_C0109	0	200 Gr	Grasso - Grease	1
5	200A00003	1		(3pcs) - Connettore - Connector	1
5	200A00001	0		(10pcs) - Connettore - Connector	1
5	200A00050	0		(50pcs) - Connettore - Connector	1
6	042Z58600A	0		Copertura base di ricarica - Docking station cover	1

Solo per rivenditori
 Only for dealer

Code	(IT) Descrizione * (GB) Description	MOQ
CS_BT_USB	Convertitore USB-Bluetooth - USB-Bluetooth Converter	1



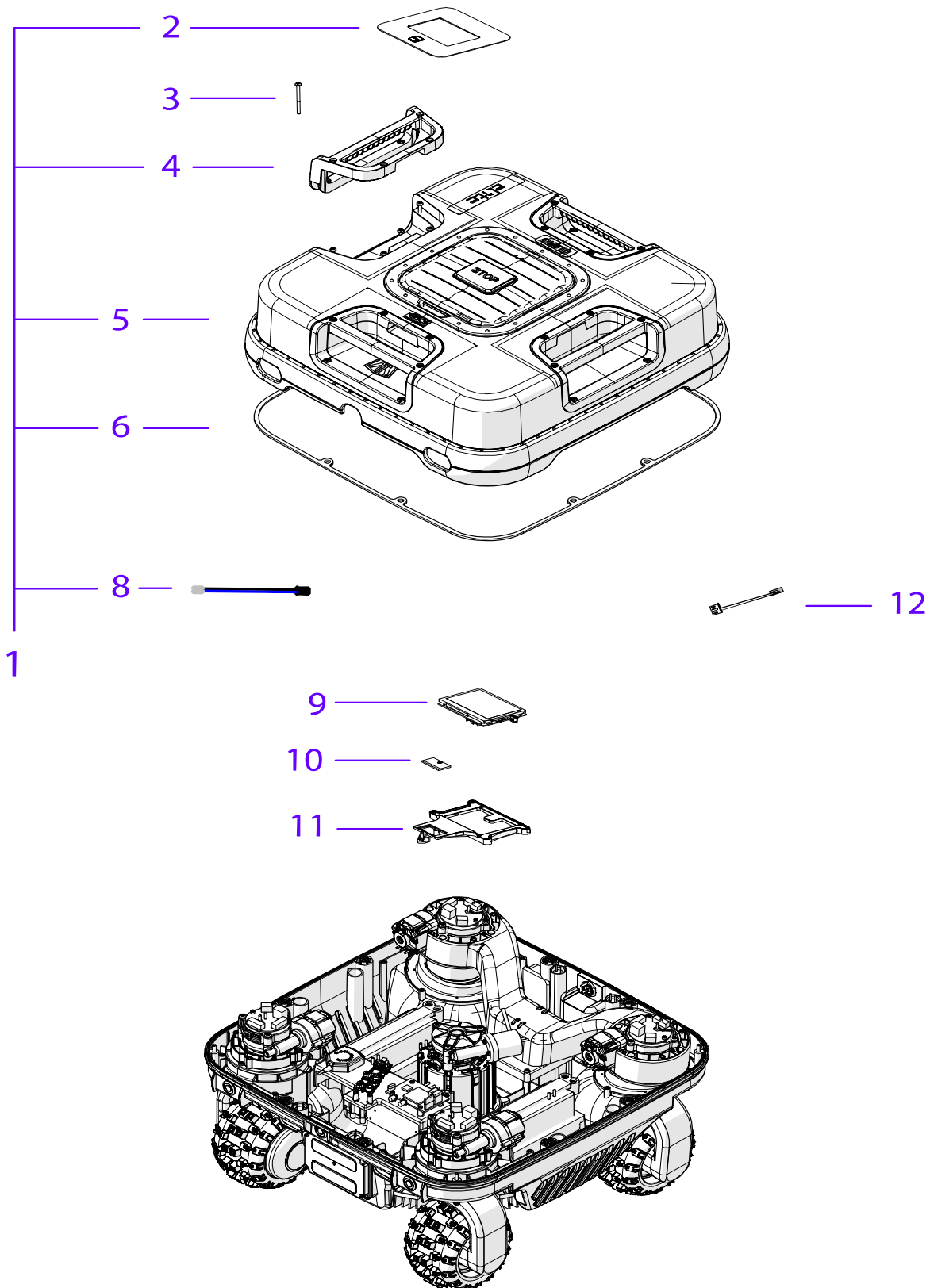

Rif.	Code	Qt.in Robot		(IT) Descrizione * (GB) Description	MOQ
1	075Z57500C_R	1	Ambrogio	Assieme calotta CUBE - Cap set CUBE	1
2	075Z54300A_R	1		Tastiera display QUAD - Keyboard QUAD	1
3	C02560	8		Vite Torx M4x45 - Torx screw M4x45	10
4	075Z52800A_R	4		Maniglia QUAD - Handle QUAD	1
5	075Z53000B_R	1	Ambrogio	Calotta con paraurti - Cover with bumper	1
6	075Z51700A	1		Guarnizione - Gasket	1
7	075Z54700A_R	4		PCB Radar - PCB Radar	1
8	CB010_L30	1		Cablaggio sensore pioggia - Rain sensor Cabling	1
9	075E01700A_R	1		Display touch - Display touch	1
10	075E02800A_R	1		Sensore tasto STOP - STOP button sensor	1
11	075Z53400A_R	1		Supposto display - Display support	1
12	110E01100A	1		Cablaggio Terminazione CAN - CAN termination cable	1

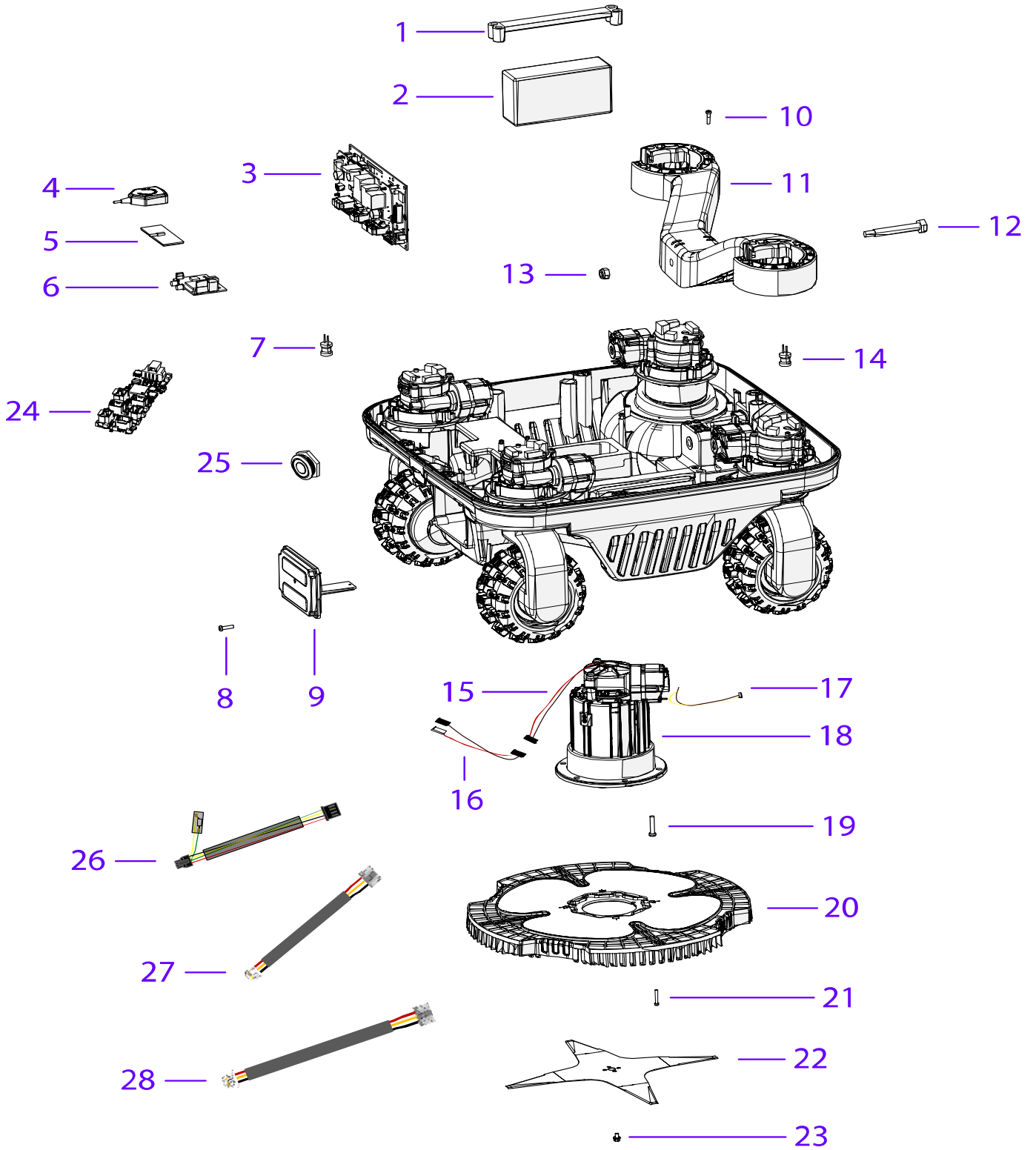

Tav.
Tab.
Taf.

03

0

Rif.	Code	Qt.in Robot	(IT) Descrizione * (GB) Description	MOQ
1	051Z14700A	2	Staffa batteria - battery bracket	1
2	075Z60900A_R	2	Batteria - Battery	1
3	075E02500A_R	1	Scheda madre QUAD - QUAD motherboard	1
4	C01219_R	1	Antenna GPS - GPS Antenna	1
5	C02455_R	1	Antenna GSM - GSM Antenna	1
6	015E01300A	1	Modulo Connect 4G ME910 - Connect Module 4G ME910	1
7	110E00700A	2	Bobina - Coil	1
8	C02548	4	Vite Torx 4X16-A2 - Torx screw 4X16-A2	10
9	075Z50100A_R	1	Modulo contatto ricarica - Contact recharge module	1
10	C02356	14	Vite Torx 4X16-A2 - Torx screw 4X16-A2	10
11	075Z50500A_R	1	Bilanciere - Balancer	1
12	075Z49000A	1	Perno cerniera - Hinge pin	1
13	C01486	1	Dado M8 - Nut M8	10
14	051E01400A	2	Bobina - Coil	1
15	051CB05.00	1	Cablaggio motore - Motor wiring	1
16	051CB04.01	1	Adattatore cablaggio motore - Motor cabling adapter	1
17	400CB03.01	1	Alzalama cablaggio - Blade raiser wiring	1
18	075Z57300A_R	1	Assieme motore lama - Blade motor assembly	1
19	C02547	6	Vite Torx 5X25-A2 - Torx screw 5X25-A2	10
20	075Z51300A_R	1	Protezione lama - Blade guard	1
21	C02172	4	Vite - Screw	10
22	075Z56500A_R	1	Lama piegata 4 punte - 4 knife blade	1
23	C00212	4	Vite - Screw	100
24	075E03001A	1	Modulo HUB - HUB Module board	1
25	075Z95421A	6	Sensore USS - USS Sensor	1
26	075CB08.01	1	CPU - HUB Cablaggio modulo HUB - HUB Module cabling	1
27	075CB09.01	3	USS - HUB (back) Cablaggio Radar_HUB - Radar to HUB cabling	1
28	075CB10.03	1	USS - HUB (front) Cablaggio Radar_HUB - Radar to HUB cabling	1

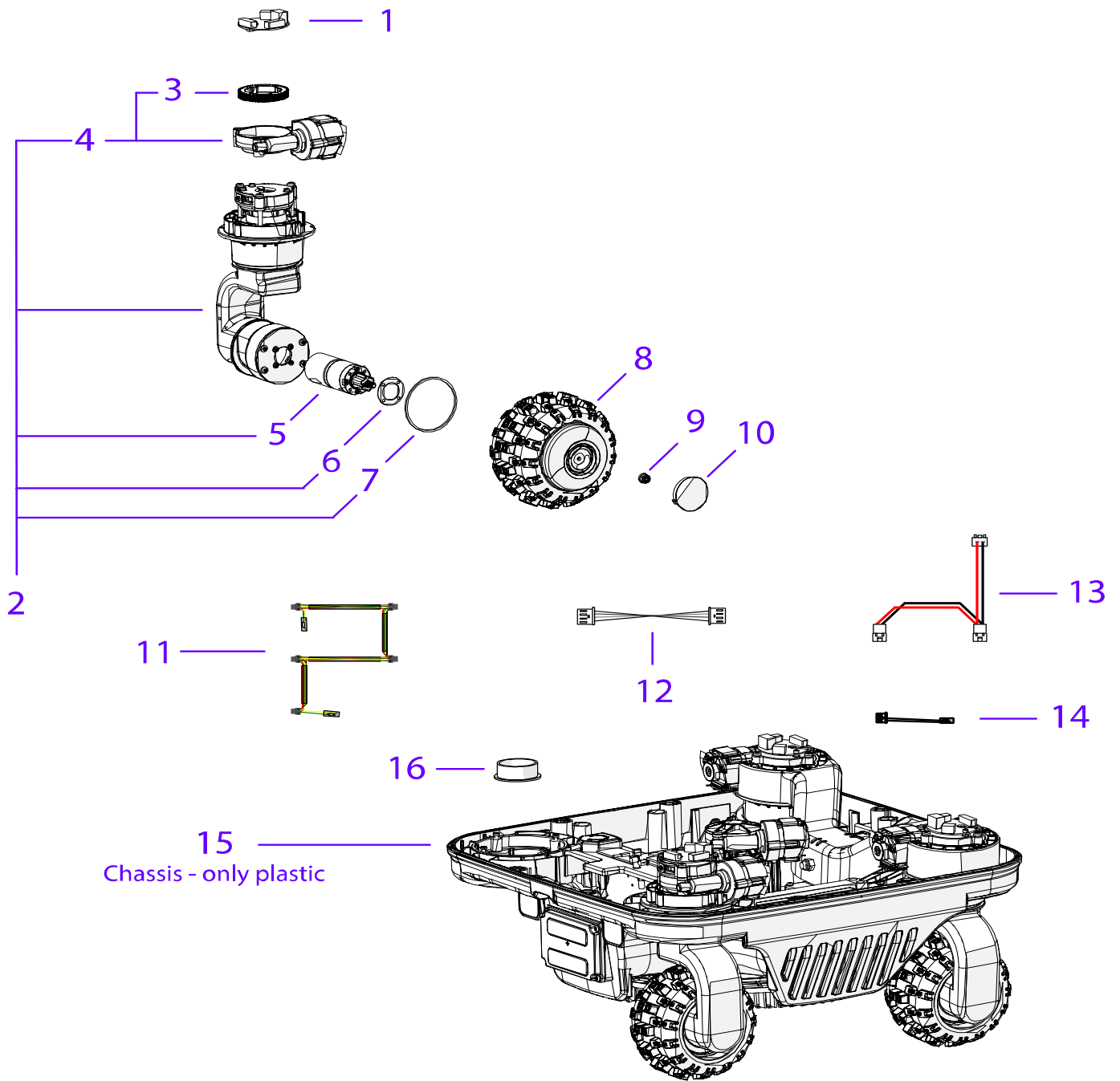

Rif.	Code	Qt.in Robot	(IT) Descrizione * (GB) Description	MOQ
1	075E02000A_R	4	Scheda driver - Driver board	1
2	075Z47500B_R	4	Assieme modulo ruota - Wheel module assembly	1
3	075Z48400A	4	Ruota dentata - Gear	1
4	075Z48600A_R	4	Motore sterzo - Steering motor	1
5	075Z01306A_R	4	Motore trazione anteriore - Front driving motor	1
6	015Z14700A	4	Guarnizione - Gasket	10
7	015Z14800B	4	Guarnizione - Gasket	10
8	075Z49700C	4	Ruota trazione - Traction wheel	1
9	C00128	4	Rosetta dentellata - Toothed washer	10
10	075Z51900A	4	Tappo ruota - Wheel plug	1
11	075CB01.03	1	Cabl. CAN driver - AM4000 - CAN cable - driver to AM4000	1
12	042CB01.01	2	Cablaggio - Wire	1
13	050CB01.01	1	Cablaggio batteria - Battery cable	1
14	110E01100A	1	Cablaggio Terminazione CAN - CAN termination cable	1
15	075Z53500B_R	1	Scocca - Chassis	1
16	C02426	8	Boccola - Bushing	1

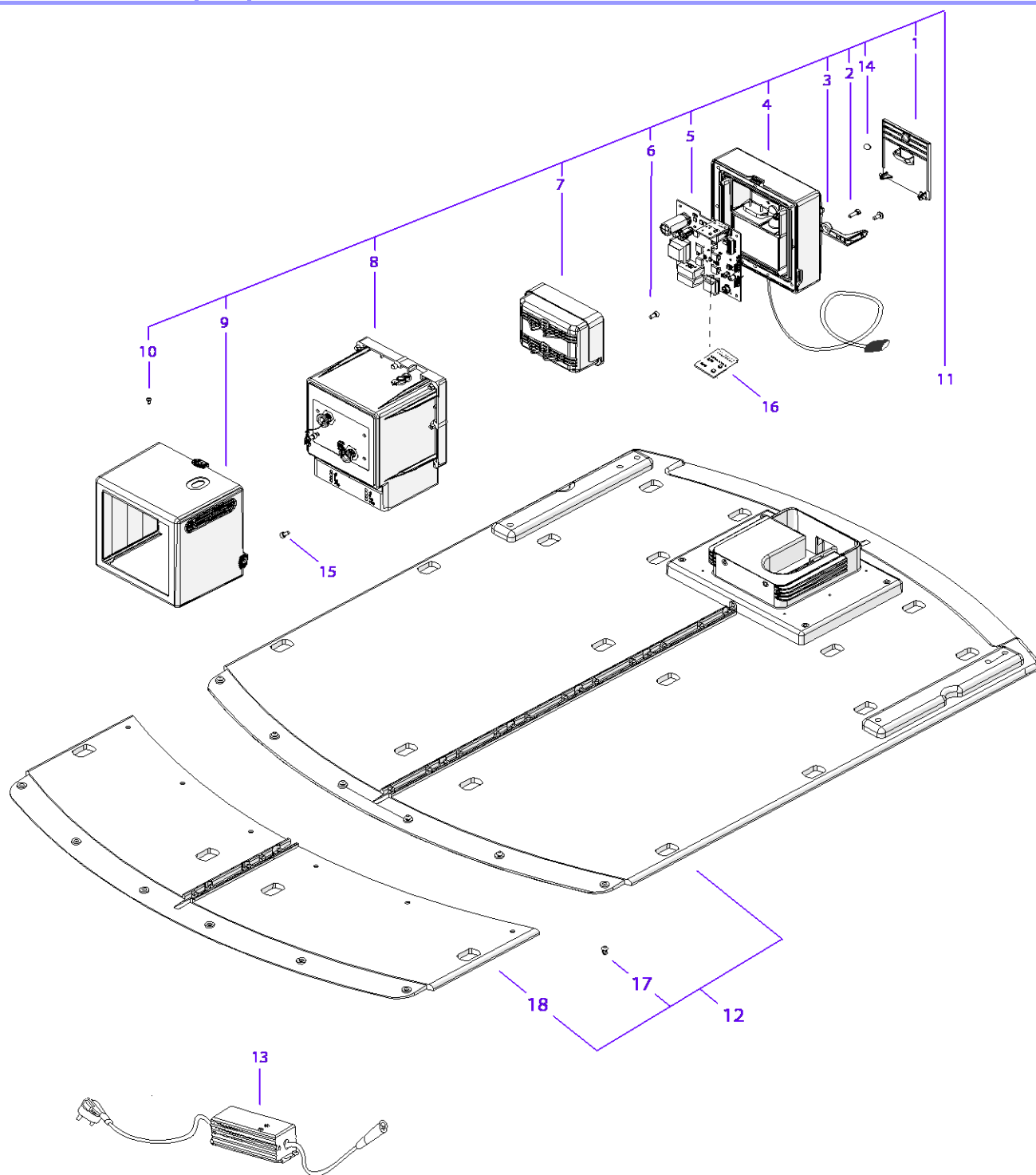

Tav.
Tab.
Taf.

05

0

Rif.	Code	Qt.in Robot		(IT) Descrizione * (GB) Description	MOQ	
1	042Z37200A	1		Coperchio posteriore - Back cap	1	
2	C02172	8		Vite - Screw	10	
3	042Z24500A	1		Fermacavo - Cable clamp	1	
4	042Z27300A	1		Chiusura base ricarica - Docking Station Closing	1	
5	042E00500A	1		Trasmittitore - Trasmittiter	1	
6	C02224	4		Vite - Screw	10	
7	042Z24800A	1		Gruppo contatti ricarica - Recharging contact group	1	
8	042Z44500A	1	Ambrogio	Torretta base di ricarica - Docking Station Tower	1	
9	042Z53000A	1		Copertura torretta - Tower cover	1	
10	C02244	3		Vite - Screw	10	
11	042Z26500A	1	Ambrogio	Box trasmettitore (Bianco) - Transmitter box (White)	1	
12	042Z52800A	1		Pianale - Floor	1	
13	ELG-240-30	1		(8A) Caricabatteria - Battery Charger	1	
14	042Z32000A	1		Magnete - Magnet	1	
15	C00908	2		Vite - screw	10	
16	015A00700A	1		Scheda LED trasmettitore - LED transmitter board	1	
17	C01294	6		Rivetto - Rivet	10	